

## ELBA Module EMS 500

**ELBA-Module EMS 500** consisting of the base frame made of beams with the mixer, weighing frame and skip hoist drive for the installation on existing mixer platforms. Module completely pre-mounted. Ladder from the base frame to the service platform. Electric installation on terminal boxes.

**ELBA High-efficient Single-Shaft Compulsory Mixer EMS 500**, in stationary execution. Dual-zone-counterflow mixing action. Mixer lining and mixer spirals are fitted with replaceable and highly wear-resistant steel tiles. Special mixer shaft seals with automatic lubrication. Pneumatically operated discharge gate and discharge funnel. Cleaning flap with quick lock and safety switch. Possibility of mounting an Air-Bag or filter system (see accessories).

drive	geared motor 18,5 kW, 400 V, 50 cycles
nominal volume (acc. to DIN 459)	500 l (compacted fresh concrete)
nominal volume (acc. to DIN 459)	625 l (non-compacted fresh concrete, Factor V = 1,25, acc. to DIN 1045)
pneumatically operated discharge gate	
air consumption per double stroke	42 l (uncompressed air)
operating pressure	4 – 6 bar

**Weighing frame** with electronic cement weigher, ready to operate, mounted on top of the mixer. Prepared for the installation of the electronic water weigher or of the water meter (see accessories).

weighing capacity of cement weigher	0 – 300 kg
number of cement inlets	4
pneumatically operated discharge gate	
pneumatic vibrator for discharge	
load cells with PTB/EG approval	
three-point-suspension	

**Skip hoist** with pole-changeable drive. Hoist track and drive unit up to the base frame. Including all safety switch-off. End piece of the skip hoist feasible as weigher (see accessories).

drive	14 kW / 12 kW, 400 V, 50 cycles
speed	0,4 m/sec and 0,8 m/sec
inclination	60 degrees (other inclinations possible as project)
volume of bucket	750 l
travelling distance	max. 18 m

### Accessories

- water flow meter	0 – 200 l
- electronic water weigher	weighing range 0 – 150 kg / round, hot galvanized execution
- air-bag	closed volume compensating system to prevent cement dust emission
- filter system consisting of:	suction filter 3,7 m <sup>2</sup> , ventilator 0,5 kW
- track extension	in meter / from upper part of mixer platform
- aggregate weigher	in electronic execution mounted at the end part of the hoist track, weighing range 1500 kg
- mixer platform	in steel construction including covering and railing as well as galvanized staircase with grids. Length=4,5 m, Width=4,5 m, Height=5,6 m
- weather cladding	in trapezoidal sheet execution for the mixer platform and skip hoist well. Including roof, 2 doors (mixer platform, skip hoist) and 4 windows (1,0 m x 1,0 m)
- winter cladding	isolated cladding of the mixer platform, skip hoist well and roof. Execution with TL 40 elements. Isolated glass 4 windows (1,0 m x 1,0 m) as well as 2 doors. (execution with TL 66 against extra price)
- remote indicators of weighers	in calibrated or not calibrated execution (acc. to requirements)
- high voltage unit	switch cabinet for separate installation
- controls of the plant	for separate installation
- additive weigher	execution ES with discharge pumps
- safety protections	protection in the area of the hoist track
- miscellaneous	batching units / compressor

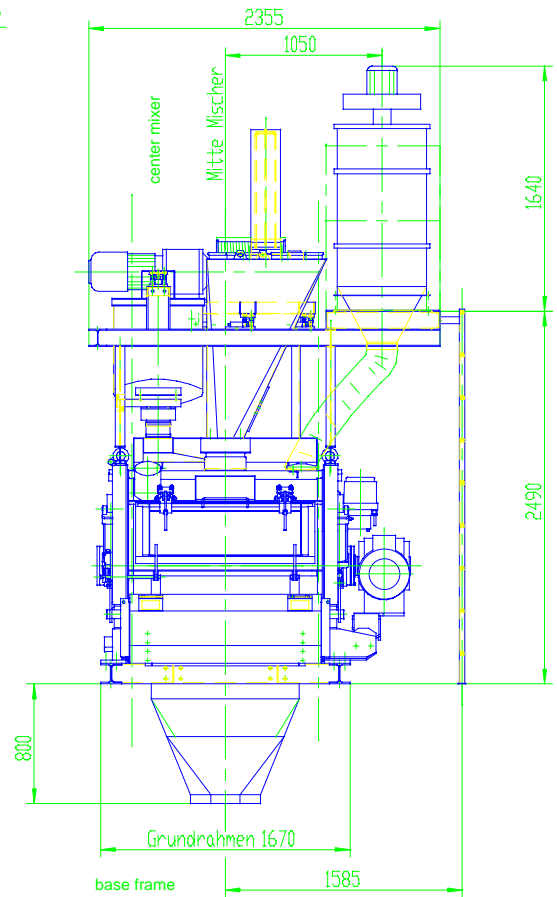
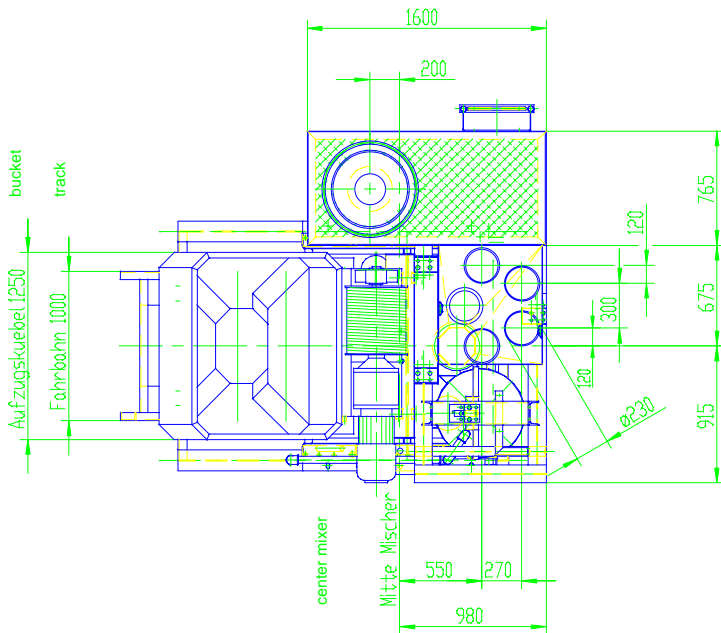
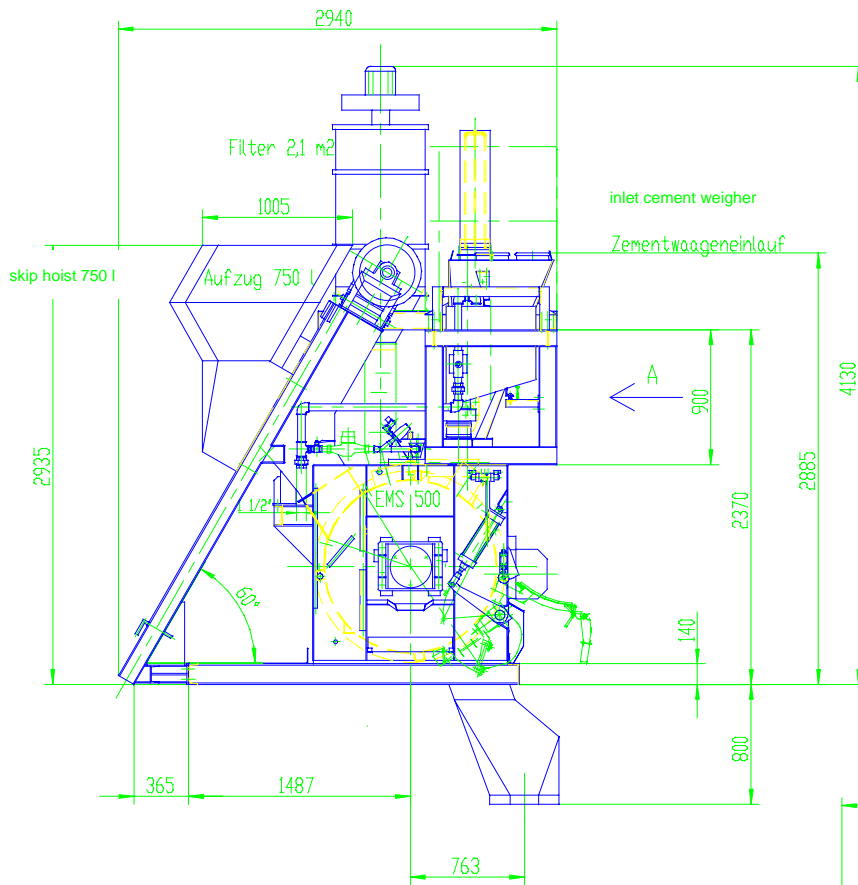

Ansicht A view A

009.35-0320.1 (0.08.5.0)

Technische Änderungen vorbehalten.  
Subject to technical changes.

Sous réserves de modifications techniques.  
Sujeto a modificaciones técnicas.